

A New High Power IC Surface Mount Package: PowerSO-20™ Power IC Packaging from Insertion to Surface Mounting

by P. Casati and C. Cognetti

A new, high power IC surface mount package family is introduced in this note. It is called PowerSO family and has the Jedec registration MO-166.

SGS-THOMSON developed PowerSO in order to answer the increasing demand of miniaturization and quality in power applications. Automotive, industrial, audio and telecom markets will take advantage of the new package, by introducing the use of Surface Mount Technology in the production of power systems.

PowerSO-20 is the element of the MO-166 family having 20 leads at 0.050 inch pitch (1.27 mm). At present (early 1994) it is starting up in volume production.

This note is intended to compare the PowerSO-20 with alternative surface mount solutions and to the existing Multiwatt package, the well known "double TO-220" developed by SGS-THOMSON in late 70s.

Data presented here demonstrates that

PowerSO-20 is the real successor of Multiwatt for surface mount applications and can become a milestone in power package technology as Multiwatt did 15 years ago.

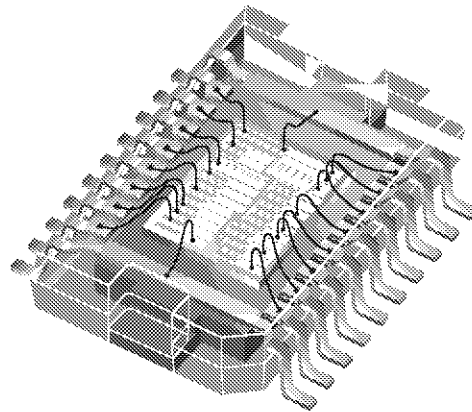

PowerSO-20™ – Jedec Registration MO-166

1. POWER DEVICES AND SURFACE MOUNTING

Use of Surface Mount Technology (SMT) has dramatically increased in the last 12-15 years, moving from consumer to professional applications and serving highly demanding markets like telecom, industrial and automotive.

Major advantages expected from SMT are size reduction, automated board mounting, high reliability and cost effectiveness; larger density of functions is achieved in smaller systems.

Evolution of SMT drove the development of several new packages for discrete and IC devices: SOT23, SOT194, TO263, SO, PLCC, PQFP with many options in pin pitch, size and thickness.

All of them are compatible with the surface mount technique, based on fast picking and placing from tapes or trays, followed by mass soldering. Mounting lines are almost totally automated, with high throughput and high yield.

Only a few devices are not yet compatible with SMT principles: a few "exotic" components like large capacitors, resistors, inductors, varistors, etc. and almost all the power semiconductor packages. Several drawbacks are associated with existing power packages:

- 1-They have still the traditional structure for insertion and are mounted manually in the PCB, with loss of time, productivity, floor space and money;
- 2-They force the use of wave soldering techniques and are not compatible with reflow soldering;
- 3-They are not compatible with increasing need of miniaturization of power systems.

The above points are so important that the development of totally new power packages fitting the SMT requirements is a clear demand of the industry and can pay back the heavy effort needed in terms of R&D, engineering and production resources.

1.1 INTERMEDIATE SOLUTIONS: INSERTION PACKAGES CONVERTED TO SMT

The fastest answer to the requirement discussed above is the adaptation of existing insertion packages to obtain a kind of surface mount configuration.

APPLICATION NOTE

This can be conveniently done by redesigning the lead shape, as in the case of the surface mount Heptawatt package (7 lead TO-220) shown in Figure 1 which was introduced in the market by SGS THOMSON in 1989.

Another example of this concept is the surface mount Multiwatt (Double TO-220) represented in Figure 2.

Both the packages of Figures 1 and 2 are very attractive in terms of capital expenditure and time to market; as a minor modification of existing production line can provide the surface mount version in a short development time.

However, the experience of SGS THOMSON with above solutions is not totally satisfactory, for a number of reasons:

Figure 1: Heptawatt (surface mount) package

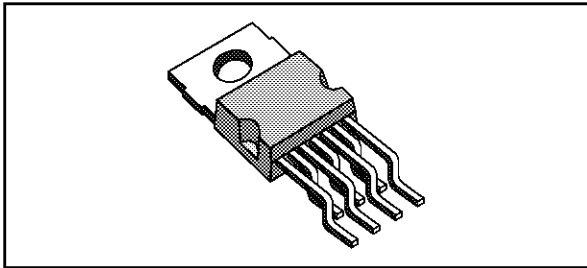
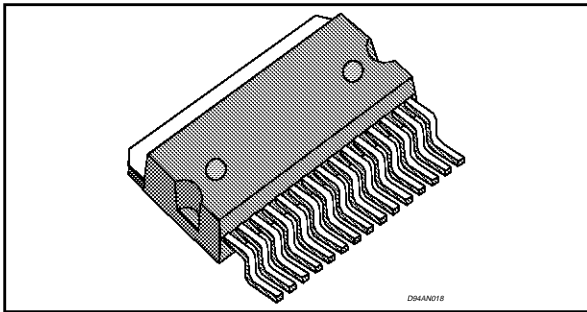

Figure 2: Multiwatt (surface mount) package



- 1) **HANDLING**, which unlike all other surface mount packages, is complicated by the structure, which is asymmetrical in two directions (height and thickness). Existing pick and place tools are not readily compatible with this structure, as well as the tape and reel packing;
- 2) **SIZE**, which is basically the same as existing insertion packages; therefore, is not the answer to the demand of miniaturization of power systems coming from almost all the applications: automotive, audio and industrial;
- 3) **COPLANARITY**, which can become an issue for 4-6 mm (0.16-0.24 inch) long leads, as those considered in Figure 2 for the surface mount Multiwatt. It must be recalled that ma-

ior coplanarity improvement is obtained by reducing the lead length, down to 1-2 mm (0.04-0.08 inch); this cannot be readily obtained with Multiwatt, whose average lead-frame thickness is about 0.5 mm (0.02 inch).

- 4) **RELIABILITY AFTER THE SOLDERING PROCESS**, due to the excess stress caused by the high temperature (>215°C) even with "zero" absorbed moisture at the large interface between slug and molded body, with consequent delamination;
- 5) **INSPECTION OF THE SOLDERED JOINT** between slug and substrate, as discussed in next paragraph;
- 6) **LIMITED PIN COUNT**, between 11 and 15, which is no longer able to cover the requirements of advanced smart power, needing more I/Os for the logic circuitry.

Due to the above reasons, SGS THOMSON preferred to invest in new especially developed power structures, with designed-in surface mount characteristics. Moreover, due to the increasing demand of quality, led by the automotive market, process and materials were selected in order to obtain intrinsic long term reliability and a very low failure rate, targeted at 1 ppm for early life.

1.2 NEW SOLUTIONS : ORIGINAL SGS THOMSON PACKAGES WITH DESIGNED-IN SMT CHARACTERISTICS

The well understood dual-in-line configuration was selected for the new housing (Figure 3), which does not look very much different than the Small Outline (SO) package; but, from high dissipation capability, the main difference is the internal massive slug, which provides the same thermal impedance as traditional insertion packages.

Figure 3: PowerSO-20 Package

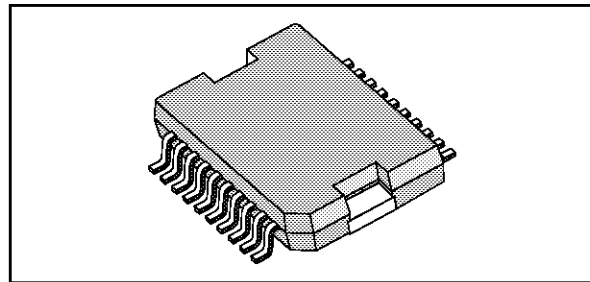

In view of the larger pin count needed for smart power products, a family of packages has been designed, covering from 20 to 36 leads. The well established concept of "variable pitch in a fixed body" has been used, with 1.27 mm (0.05 inch), 1.0 mm, 0.8 mm and 0.65 mm.

The new family, named PowerSO, is Jedec registered as MO-166.

APPLICATION NOTE

At present (1994), extensive evaluation has been performed on the member of the family having 20 leads with 1.27 mm (0.050 inch) pitch, named

PowerSO-20, which is presented in this technical note (Figure 4.).

Figure 4: PowerSO20 package (Jedec MO-166) mechanical data.

DIM.	mm			inch		
	MIN.	TYP.	MAX.	MIN.	TYP.	MAX.
A			3.60			0.1417
a1	0.10		0.30	0.0039		0.0118
a2			3.30			0.1299
a3	0		0.10	0		0.0039
b	0.40		0.53	0.0157		0.0209
c	0.23		0.32	0.009		0.0126
D (1)	15.80		16.00	0.6220		0.6299
E	13.90		14.50	0.5472		0.570
e		1.27			0.050	
e3		11.43			0.450	
E1 (1)	10.90		11.10	0.4291		0.437
E2			2.90			0.1141
G	0		0.10	0		0.0039
h			1.10			0.0433
L	0.80		1.10	0.0314		0.0433
N	10° (max.)					
S	8° (max.)					
T		10.0			0.3937	

(1) "D and E1" do not include mold flash or protrusions - Mold flash or protrusions shall not exceed 0.15mm (0.006")

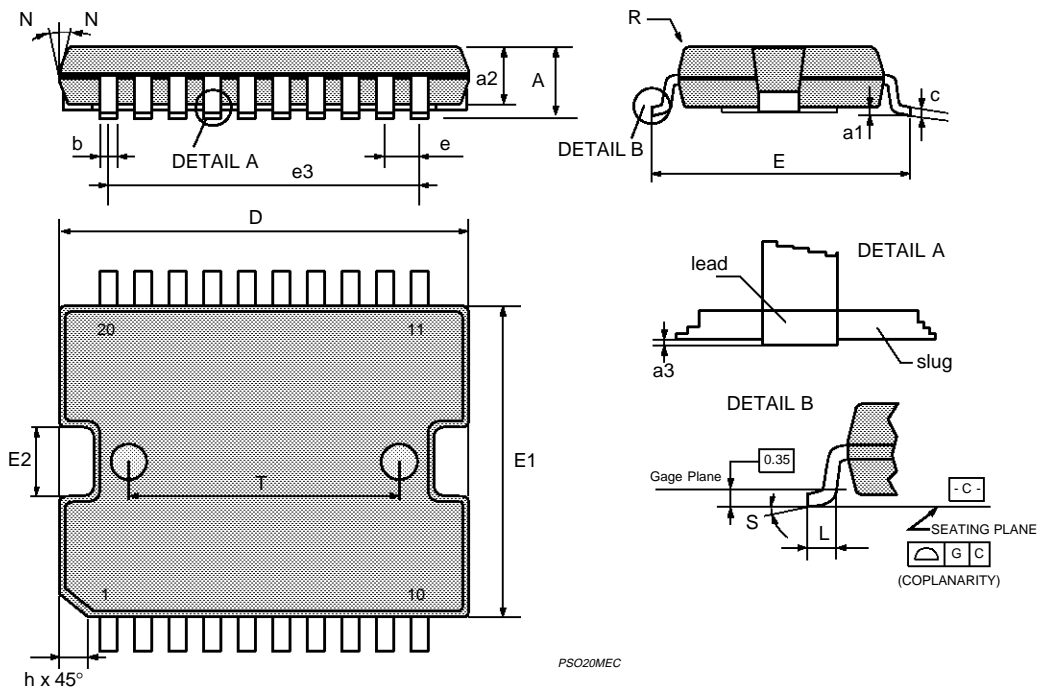

APPLICATION NOTE

The most important features of PowerSO-20 are:

- 1] High power structure and process;
- 2] High current capability;
- 3] Miniaturization;
- 4] Designed-in surface mount characteristics:
 - a] Handling;
 - b] Tape and reel packing;
 - c] Co-planarity;
 - d] Solder joint quality and inspection;
 - e] High reliability after soldering process.
- 5] Designed-in "hermeticity", for low failure rate (1 ppm).

2. STRUCTURE AND CHARACTERISTICS OF PowerSO-20™.

In this section, design criteria listed in previous paragraph are presented and discussed.

2.1 High power structure and process (>20 W)

The main feature of the power package structure is the existence of a massive copper slug in the package onto which the silicon chip is soldered. Its function is twofold:

- a) To provide a low thermal resistance path from the chip to the external heatsink;
- b) To provide a large thermal capacitance, able to absorb power peaks in switching conditions.

The slug of PowerSO-20, is optimized in order to get a good compromise between miniaturization and thermal performance. As a result of this work, PowerSO-20 has the same junction to case thermal resistance $R_{th(j-c)}$ of Multiwatt package and the same thermal impedance up to 0.5 sec. Therefore the range of application exceeds 20 W, the same as for traditional power packages.

Section 3 will present thermal design in detail. Here we will recall the importance of the die attach process, typical of power IC packages, which uses a high melting temperature (300 C) tin based alloy. The control of this process, in terms of solder thickness and void reduction, is based on SPC methods and has a CPK > 1.33.

2.2 High current capability (10-20 A)

At first glance, leads of the PowerSO-20 seem

very fragile, thin and not compatible with the high currents (10-20 A) associated with a large number of power ICs, which require the utilization of large aluminum wires having a diameter ranging between 0.010 and 0.020 inch (0.25 to 0.5 mm).

Table 1 reports the comparison of PowerSO-20 with insertion and surface mount Multiwatt and the following considerations are possible:

- 1) Electrical resistance of PowerSO-20 leads is about $760\mu\Omega$, i.e. it is equivalent to insertion Multiwatt or better;
- 2) Electrical resistance of PowerSO-20 leads is worse than Surface Mount Multiwatt by a factor of 1.3 to 2;
- 3) In any case, lead resistance of PowerSO-20 is much lower than the wire resistance. Wire resistance is $450-1800\mu\Omega/mm$ and it must be considered that the minimum wire length is 2.5 mm corresponding to $1150-4500\mu\Omega$;
- 4) If needed, two or more leads are short circuited and different frame designs have been developed providing flexible options (Figure 5). With multiple wire bonding, current capability can be very large; for 45A current, if 3 leads are used with 10 mil diameter, 3 mm long wires, electrical resistance of the inter-connection is about $2m\Omega$.

Table 1: Electrical resistance data of PowerSO-20 and Multiwatt 15 leads

Dimensions (mm)	Multiwatt15 Insertion	Multiwatt15 Surf. Mount	PowerSO-20
Long lead MW15 23x0.9x0.5 18x0.9x0.5	$970\mu\Omega$ -	- $760\mu\Omega$	- -
Short lead MW15 14x0.9x0.5 9x0.9x0.5	$590\mu\Omega$ -	- $380\mu\Omega$	- -
Lead PowerSO-20 5x0.5x0.25	-	-	$760\mu\Omega$

Copper resistivity : $1.9\mu\Omega \times cm$

Aluminum wire resistance:

Ø 10 mils: $1800\mu\Omega / mm$

Ø 20 mils: $450\mu\Omega / mm$

2.3 Miniaturization

The whole story of microelectronics has been a continuous race towards smaller products. This is also true for power systems.

The PowerSO-20 offers excellent possibilities in miniaturization, without compromising power dissipation.

From Table 2, which compares the PowerSO-20 with the surface mount version of Multiwatt, advantages in terms of size, weight, height and volume are evident. They range between 22 and 64% improvement.

Table 2: Miniaturization of PowerSO-20 vs Surface Mount Multiwatt

	SM MW15L	PowerSO-20	Difference
footprint (mm ²)	320	227	-30%
height (mm)	4.5	3.5	-22%
volume (mm ³)	1160	590	-49%
weight (gr)	5.6	1.9	-64%

2.4 Designed-in surface mount characteristics

A) Handling

The PowerSO-20 structure is similar to the SO outline, which was introduced more than 20 years ago in SGS THOMSON. Therefore, the experience associated with the different as-

Figure 5: Frame options for high current

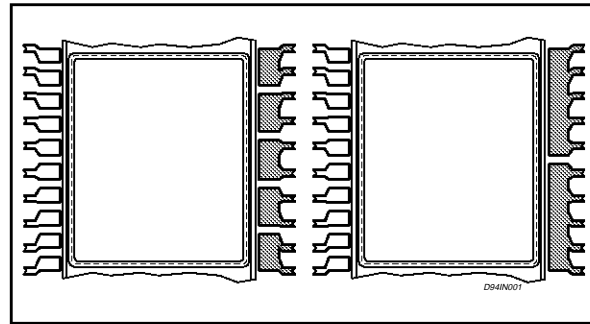

pects of production, testing, burn-in and on board mounting are quite solid.

Due to its optimized outline and reduced weight, handling of the PowerSO-20 package does not present any particular problem and is fully compatible with existing equipment.

B) Packing

Tube and Tape & Reel packing are both possible with the PowerSO-20. Embossed cavity tape has been produced with a special design, able to minimize the mechanical effect of packing and shipment on the lead coplanarity (Figure 6).

Figure 6: Embossed cavity tape.

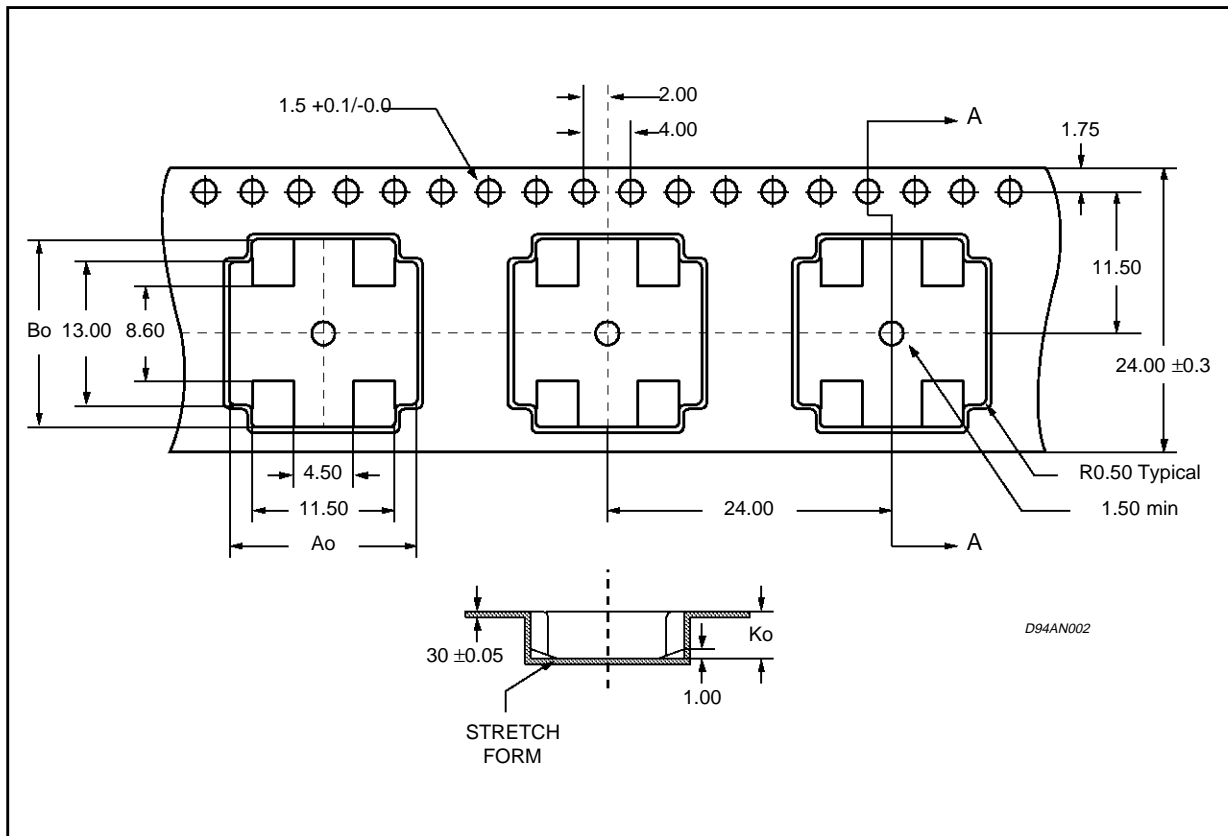

APPLICATION NOTE

C] Coplanarity

Lead coplanarity is considered a major issue for surface mount devices. In the case of Power surface mount packages, whose slug is eventually soldered on a substrate, coplanarity is also referenced to the relative position of the slug and the leads.

In the PowerSO-20, lead extremities and package slug are positioned inside a 4 mil (0.1 mm) layer; this condition provides a high yield mounting and soldering process.

D] Solder joint quality and inspection

When the package slug is soldered onto the substrate, as in the many applications developed so far, the need exists for producing a high quality solder joint between the slug and its solder pad on the board.

The PowerSO-20 structure is ideal from this viewpoint: symmetry existing in the x-y plane provides a very good balance of the wetting forces, once the solder paste is melted. A kind of self centering effect has been observed, which is mostly due to the dual-in-line outline and to the excellent wettability of both leads and slug. This results in a solder joint well controlled in thickness and consistency.

An additional advantage of the PowerSO-20 outline is the presence of two exposed inspection points on the slug, which has been intentionally obtained in the package body (Figure 7). Proprietary processes keeps these two points free of molding compound flash and allows evident solder fillets after the soldering process.

Figure 7: Exposed slug edge for solder joint inspection

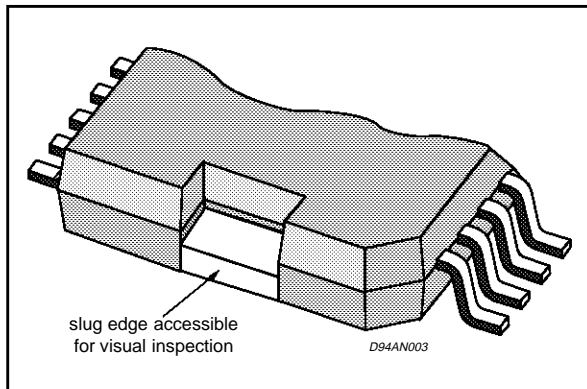

Due to the symmetrical structure of PowerSO-20, the presence of solder fillet in both inspection points is a good indicator of joint quality

and planarity. It should be noticed that the same kind of control is not possible in the surface mount Multiwatt structure, which can show a good solder fillet in the exposed section of the slug even with a non-parallel joint and possible voiding. In this case, the degradation of the junction to substrate thermal resistance $R_{th(j-s)}$ is more evident, as shown in Figure 8.

Figure 8: Loss of thermal performance due to poor co-planarity and uneven solder joints

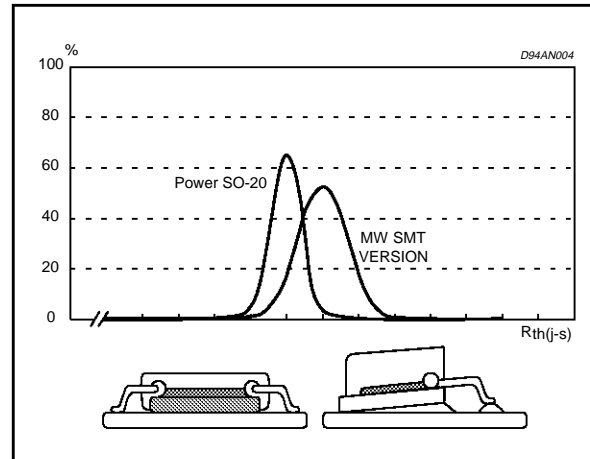

E] Reliability after soldering process

Extensive evaluation of frame design and materials provides the PowerSO-20 excellent reliability performance after the soldering process, as discussed in section 5. No degradation of the package structure has been observed after the high temperature stress, up to 260°C.

2.5 Hermeticity

Good hermeticity of package interfaces has been obtained by means of slug design and of the selection of low stress, high adhesion molding compounds.

State-of-the-art molding equipment and process is used, with CPK in excess of 1.33 for all the key parameters. This provides repeatability of the results in large volumes.

Moreover, improved mechanical clamping of the molding compound is obtained by using a new, proprietary finishing of the slug all along its periphery, which is provided with undercutting and controlled surface roughness.

After severe tests consisting of alternate thermal cycling and pressure pot, and after the "pop corn" sequence, Scanning Acoustic Microscopy (SAM) analysis and die penetration test confirms the robustness of the PowerSO-20. Figure 9 shows a typical map of adhesion obtained in SAM evaluation after stress analysis.

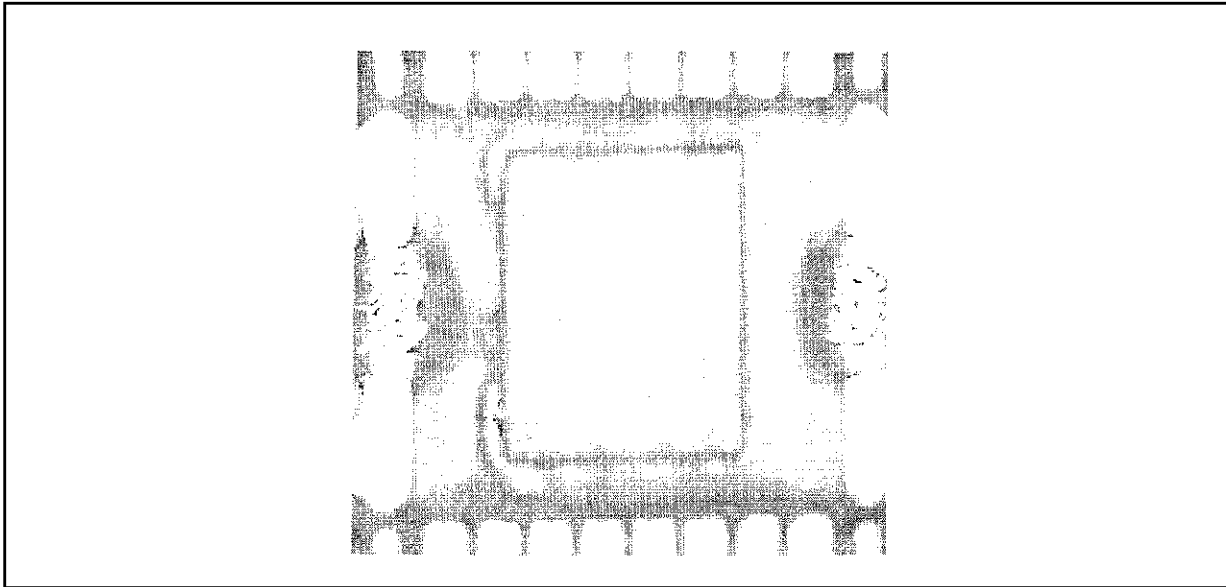
Figure 9: Scanning Acoustic Microscope map

3. THERMAL DESIGN AND APPLICATIONS

Thermal characteristics of the new PowerSO-20 package can cover a wide range of applications, both in the medium power (1-5 W) and in the high power range (up to 20 W). Moreover, as sufficiently large thermal capacitance is associated with the new package, performance in switching conditions is equivalent to that of available insertion packages.

In this section, a number of typical applications of the PowerSO-20 will be considered and compared with existing solutions, taking into account that a major role in the thermal design is played by the temperature increase $T_j - T_a$ specified in the different applications. "Delta" T_j can be as low as 25-30°C in extreme conditions for automotive or as large as 100°C in more relaxed systems.

Unless differently indicated, ΔT_j of 50°C is assumed in all the considerations of this note.

3.1 JUNCTION-TO-CASE THERMAL RESISTANCE

The main feature of PowerSO-20 package is optimization of junction-to-case thermal resistance, from the junction to the external surface of the slug.

Unlike standard SO packages, which use epoxy die attach and thin leadframes, the PowerSO-20 takes advantage of power package technology, with a massive copper slug and tin based alloy die soldering. This results in minimum junction-to-case thermal resistance $R_{th(j-c)}$. Figure 10 shows how much $R_{th(j-c)}$ is affected by the die size, assuming that the power source is uniformly distributed on the die.

For actual applications, $R_{th(j-c)}$ ranges between 2°C/W for small dice and 0.5°C/W for the maximum die size of 60k sq mils. Therefore, the PowerSO-20 is equivalent to insertion power packages like TO-220 and Multiwatt; this is due to the optimization of the slug dimensions, obtained by removal of any copper in excess, without affecting the thermal cone where the heat flows from the silicon to the substrate.

The PowerSO-20 offers a new possibility for a power package: direct soldering of the slug onto the board during the surface mount process; therefore junction to substrate thermal resistance is close to $R_{th(j-c)}$ and reaches the very attractive value of 0.5-2.0°C/W.

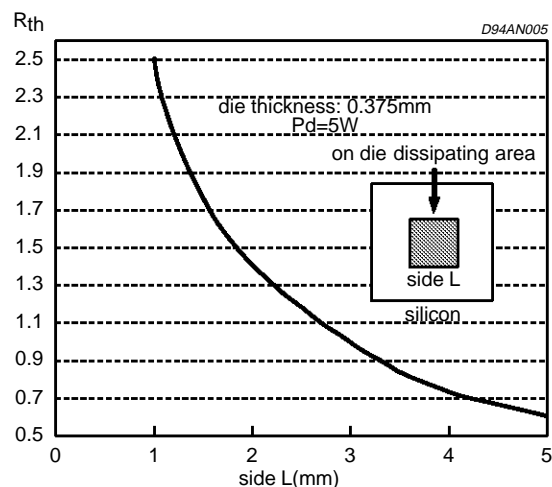
Figure 10: Thermal resistance junction-case vs. dissipating area of PowerSO-20

APPLICATION NOTE

3.2 APPLICATIONS WITH 1-2 WATT DISSIPATION

3.2.1 On board dissipating elements

In this power range, state of the art technology is based on the medium power SO.

It has the same outline of a standard SO package but with a modified leadframe in order to have a number of leads connected to the die pad (bat wing structure).

This solution, shown in Figure 11, is effective in minimizing the Junction-to-Pin thermal resistance $R_{th(j-p)}$, i.e. the thermal path between the junction and suitable dissipating areas obtained on the PCB and connected to the heat transfer leads (Figure 12).

Figure 11: Lead frame for medium power SO

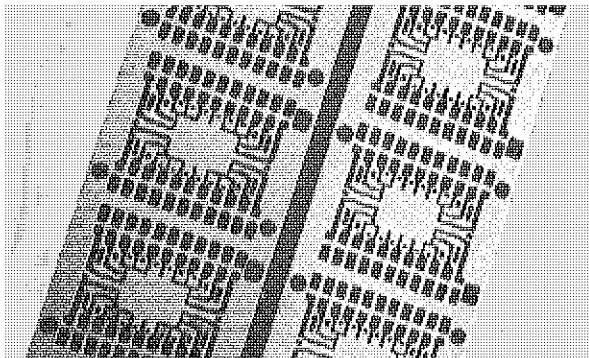
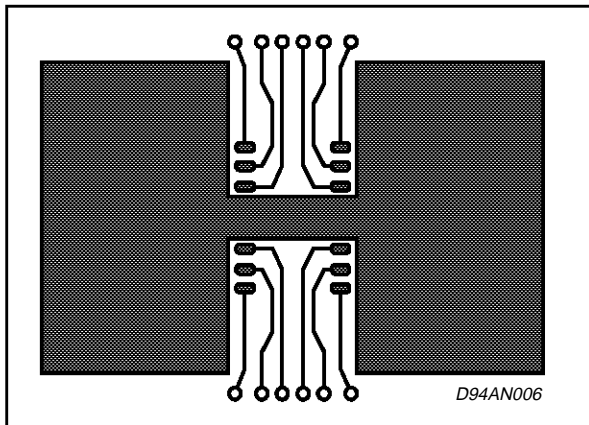

Figure 12: Foot print for medium power SO



Typical representatives of the medium power SO package family are the 300 mils SO20 and SO28 with 8 heat transfer leads, reported as SO(12+4+4) and SO(20+4+4) respectively.

Referring to SGS THOMSON guideline "Thermal management in Surface Mount Technology" (July 1988), thermal performance of medium power SO(12+4+4) is defined by the relationship:

$$R_{th(j-a)} = R_{th(j-p)} + R_{th(sub-amb)}$$

where $R_{th(j-p)}$ is the thermal path from the junction to the board and $R_{th(sub-amb)}$ is the thermal resistance of the two areas shown in Figure 12.

$R_{th(j-p)}$ ranges between 12 and 14°C/W, depending on the efficiency of the heat transfer leads (design and thermal conductivity) and on the die size.

$R_{th(j-a)}$ is due to the size of the dissipating elements on the board, according to Figure 13, which shows improved thermal resistance from 76 to 50°C/W when the dissipating area is increased from 0 to 6 cm sq.

The PowerSO-20 can be used in place of medium power SO, with the slug soldered on the board.

Figure 13: $R_{th(j-a)}$ vs. board dissipating area

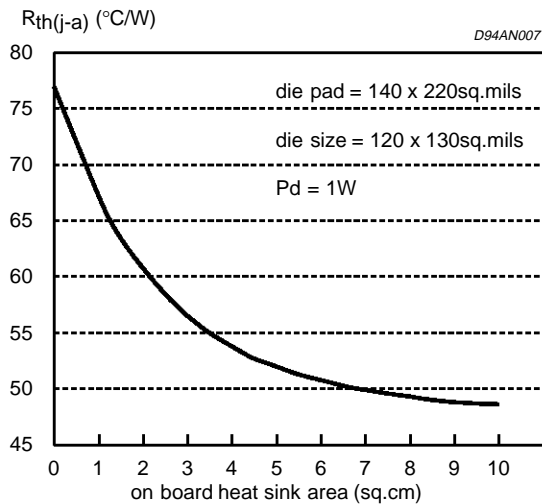

The first experimental evidence shows a very good heat exchange with the substrate, due to the large contact area associated with the basic footprint of Figure 14. $R_{th(j-a)}$ is about 50°C/W in this configuration.

Figure 14: Pad layout

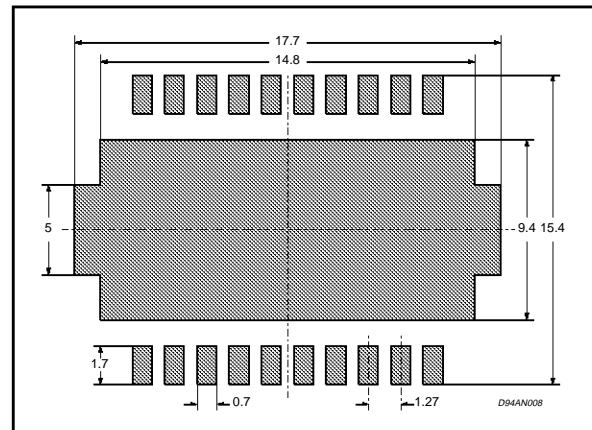

When the two dissipating elements are added and the footprint of Figure 15 is used, additional improvement is observed. For example, $R_{th(j-a)}$ is 35°C/W with dissipation elements of 6 sq cm.

Figure 15: Footprint with dissipating element

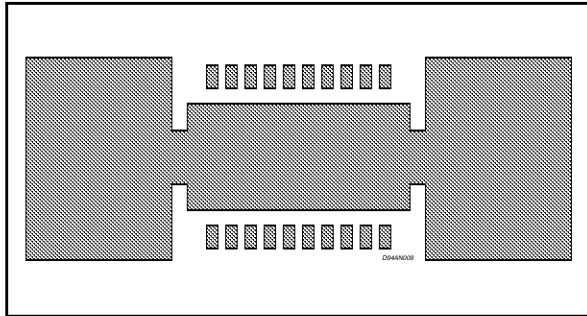

Margin over the traditional medium power SO(12+4+4) is about 40%, with dissipation increased from 1 W to 1,4 W always with $\Delta T_j = 50^{\circ}\text{C}$. Improvement can be also understood taking into account that the junction to substrate thermal resistance is equivalent to $R_{th(j-p)} = 12\text{-}14^{\circ}\text{C/W}$ for medium power SO(12+4+4) and equivalent to $R_{th(j-c)} = 0.5\text{-}2.0^{\circ}\text{C/W}$ for PowerSO-20.

3.3 APPLICATIONS WITH 2-5 WATT DISSIPATION

3.3.1 Dissipating elements and ground layer

It must be noticed that previous data are observed with a simple PCB, with single or double face. In applications using multilayer boards, a much better efficiency is observed due to the heat spreading effect of the ground layer.

Looking at the board structure of Figure 16, heat generated at the junction is transferred to the dissipating areas on the board surface and then to the ground layer, which works as a large heat exchange element with the ambient.

$R_{th(j-a)}$ offered by this solution is $20\text{-}25^{\circ}\text{C/W}$ for 2.0 - 2.5W dissipation.

Figure 16: Mounting on PCB with ground layer

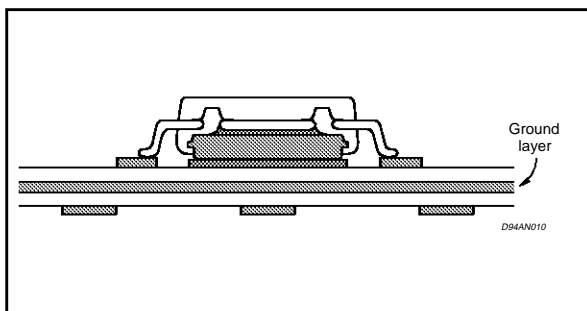

3.3.2 Via holes and ground layer

If via holes are used as in Figure 17, a more direct thermal path is obtained from the slug to the ground layer. The number of vias is chosen according to the desired performance.

$R_{th(j-a)}$ can be reduced down to $15\text{-}20^{\circ}\text{C/W}$ and dissipation increased up to 2.5-3.3 W with $\Delta T_j = 50^{\circ}\text{C}$.

Figure 17: Mounting on epoxy FR4 using via holes for heat transfer of ground layer

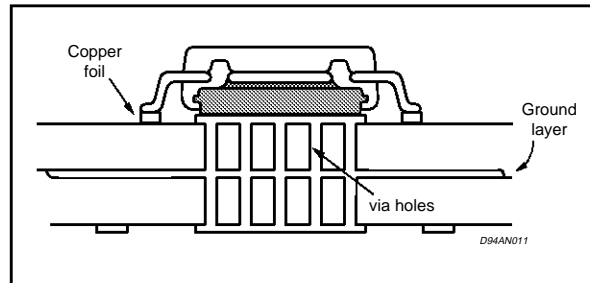

3.3.3 Via holes and external heatsink

The solution considered in Figure 18 combines a PowerSO-20 soldered onto a via hole structure, with a metal plate glued on the opposite side of the board.

The final thermal resistance value is given by the resistance of via holes added to the resistance of the plate to the ambient.

Figure 19 shows the thermal resistance associated with 16 holes and reports its behavior with the dissipated power. Hole depth of 1.5 mm is an extreme case, existing in rather thick substrates only; the experimental value is about 9°C/W , including the contribution of $R_{th(j-c)}$. In practical cases, structures with $R_{th(j-a)} = 12\text{-}15^{\circ}\text{C/W}$ are obtained for 3.3-4.2W dissipation.

Figure 18: Mounting on epoxy FR4 using via holes for heat transfer and external metal plate

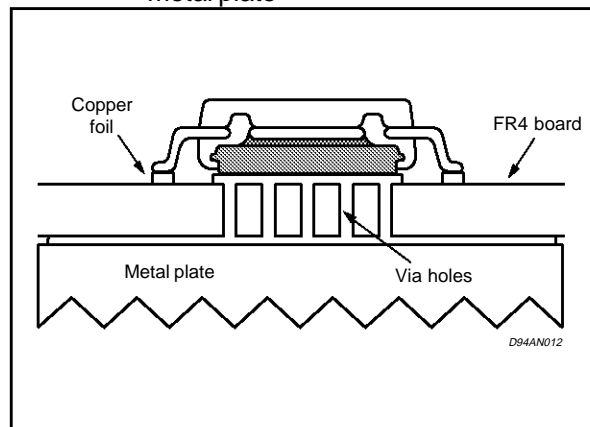

APPLICATION NOTE

Figure 19: Thermal Resistance junction-substrate

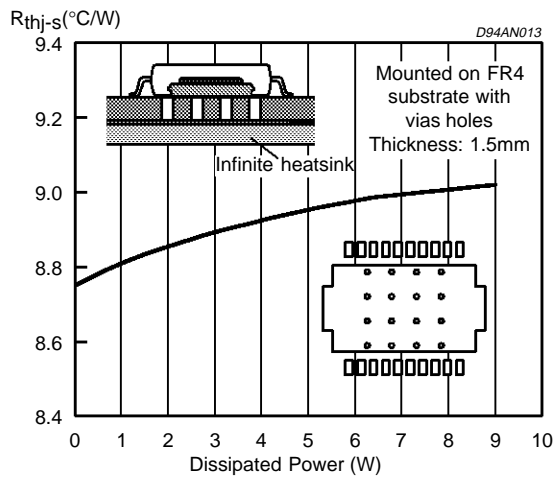

3.4 HIGH POWER APPLICATIONS (UP TO 20 W) WITH STANDARD SUBSTRATE

In order to get an $R_{th(j-a)}$ of few $^{\circ}C/W$, high power applications require large and massive external heatsinks in close contact with the power device.

At present (1994) this is not a simple requirement when cost effective systems using the standard surface mount technology and the standard PCB substrate are considered.

Major concerns are related to the critical assembly of a large heatsink onto a small package; vibrations and thermal excursions can generate unwanted mechanical stress, thus damaging the package leads or the integrity of the contact between slug and heatsink.

However, the fact that we have a well established, PCB based surface mount technology is pushing the industry to test several directions, similar to those sketched in Figure 20.

Rather than proven solutions, they should be considered here as early attempts aimed to explore the capability of existing surface mount processes and materials in the direction of increased heat dissipation at reduced cost.

3.4.1 "Slug-up" package and external heatsink

In the example of Figure 20a, PowerSO-20 is shown in "reverse" or "slug-up" configuration, with a clip mounted external heatsink, which was studied for 3.5W dissipation in still air and 5-6 W dissipation in forced ventilation.

A similar concept can be used for other applications and the sink size adapted to their specific requirements. A large variety of solutions will exist which will take advantage of the metal box in which the board can eventually be housed.

Figure 20a: "Slug up" package with external heatsink

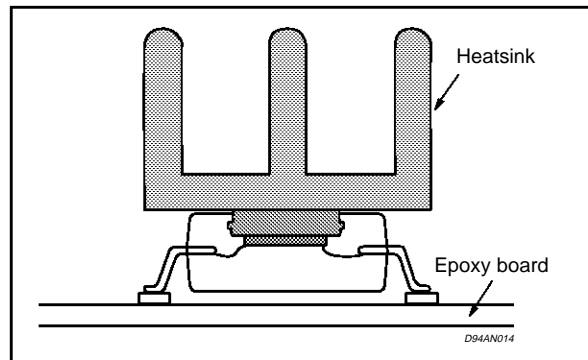

3.4.2 Cavity board and external heatsink

In the example of Figure 20b, the PowerSO-20 is mounted onto an epoxy board, with a through cavity fabricated to correspond to the package slug. The external heatsink is directly applied in contact with the slug, secured by means of a spring system or glued. Also in this case, a high level of dissipation can be achieved with properly designed heatsinks.

Figure 20b: Mounting on cavity board and external heatsink applied

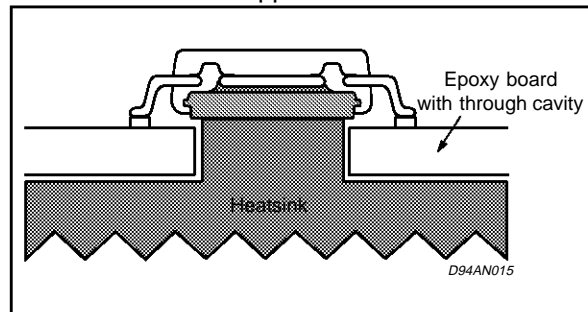

3.5 HIGH POWER APPLICATIONS (UP TO 20W) WITH INSULATED METAL SUBSTRATES - IMS

In the last few years, several Companies developed the idea of a cost effective Insulated Metal Substrate (IMS) having:

- A copper printed layer supported by an aluminum base, with epoxy or polyimide isolation in between; or
- A flexible printed circuit (polyimide) glued onto an aluminum base.

In both cases, the following conditions are offered:

- The substrate is compatible with standard SMT processes, including infrared reflow soldering;

- b) It is compatible with passive and active devices, including PowerSO-20;
- c) It has an acceptable thermal resistance loss between the PowerSO-20 slug and the aluminum base, due to optimized thermal conductivity of the isolating layer;
- d) The aluminum baseplate has variable thickness, up to 5 mm, in order to sink different amounts of heat.

Utilization of IMS is considered for several applications both for automotive and industrial systems and is particularly fruitful when associated with the PowerSO-20 package (Figure 21).

Figure 21: Mounting on IMS board

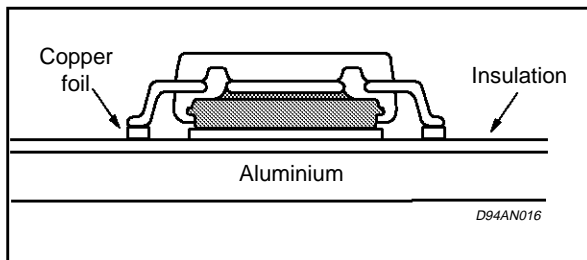

Thermal performance has been measured for both substrates described above. The first result is related to the contribution of isolation to the total thermal resistance. When the footprint of Figure 14 is used, with the 96 sq mm slug soldered onto a 155 sq mm pattern, this contribution is about 0.5°C/W.

Therefore, the thermal resistance from the junction to the aluminum baseplate ranges from 1.0 to 2.5°C/W depending on the chip size.

For large dissipation, an external heat sink is applied to the IMS by means of screws, bolts or rivets. The total thermal resistance is obtained by adding the heat sink resistance to the junction to baseplate resistance (1.0-2.5°C/W).

This solution is capable of 20-25 W per device and if a large sink is used, as massive parts existing in the car, more than one device can be assembled on the same ISM, thus obtaining a functional power subsystem with several tens of Watt dissipation.

It is interesting to notice that the aluminum plate itself has good dissipation properties to the ambient, depending on its size.

The PowerSO-20 soldered onto a 40 mm square, 1.5 mm thick IMS shows a thermal resistance of 7 C/W, for about 7 W dissipation.

3.6 HIGH POWER PULSES AND THERMAL IMPEDANCE

In several applications, large power pulses are delivered by the device for a short time.

In this case, discussed in the SGS THOMSON paper "Designing with Thermal Impedance" (Semitherm Conf. 1988), the quantity which rules the junction temperature up to the time t_0 is the thermal impedance of the three different elements: silicon chip, package slug and heatsink.

For pulse durations in the range of 0.1-1.0 sec, the package slug has the strongest influence on the system performance, depending on the associated thermal capacitance, i.e. the capability of heat accumulation.

In the presence of properly sized slugs with suitable capacitance, it is possible to maintain a low junction temperature for the switching time of most applications, which seldom exceeds 1 sec.

For popular power packages like TO-220 and Multiwatt, the value of the thermal impedance in the first second is lower than the value of $R_{th(j-c)}$ in steady state.

In order to compare the PowerSO-20 package with the insertion equivalent, Fig. 22 is very helpful. It shows the thermal impedance of different packages in the first second of the power pulse, in the same conditions of power intensity and die size.

When similar comparisons are performed with medium power "bat wing" SO, the enhancement provided by the copper slug becomes very evident (Figure 23).

Due to the thermal capacitance of the slug, the transient thermal impedance of PowerSO-20 after 1 sec pulse duration is 4 times lower.

A summary of the thermal performance of the PowerSO-20 considering the different mounting approaches is given in Table 3, assuming that the maximum rated temperature of the device is 150°C and that the ΔT_j is 50°C.

Table 3: Thermal performance (ΔT_j : 50°C)

PowerSO-20 package mounted on		$R_{th(j-a)}$	Pdiss
1.	FR4 using the recommended pad lay-out	50°C/W	1.0W
2.	FR4 with heat sink on board (6 cm ²)	35°C/W	1.4 W
3.	FR4 with heatsink (6 cm ²) and ground	20°C/W	2.5W
4.	FR4 with 16 via holes and ground layer	15°C/W	3.3W
5.	FR4 with 16 via holes and external heatsink	12°C/W	4.2W
6.	IMS floating in air (40cm ²)	7°C/W	7W
7.	IMS with external heatsink applied	2.5°C/W	20W

APPLICATION NOTE

Figure 22: Thermal impedance of different packages

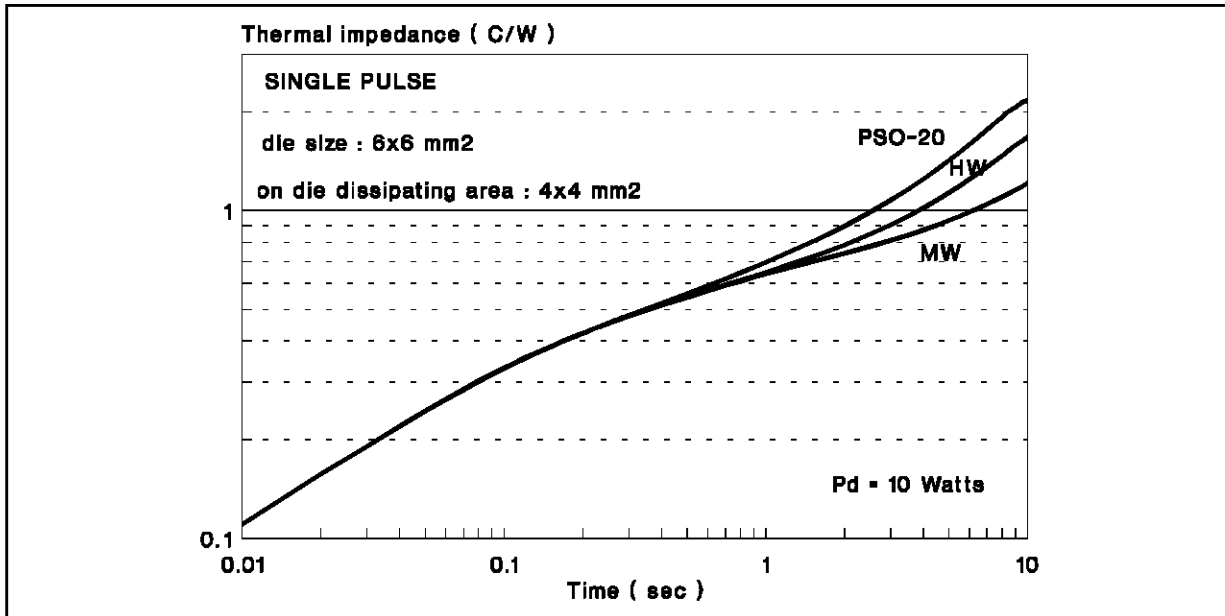
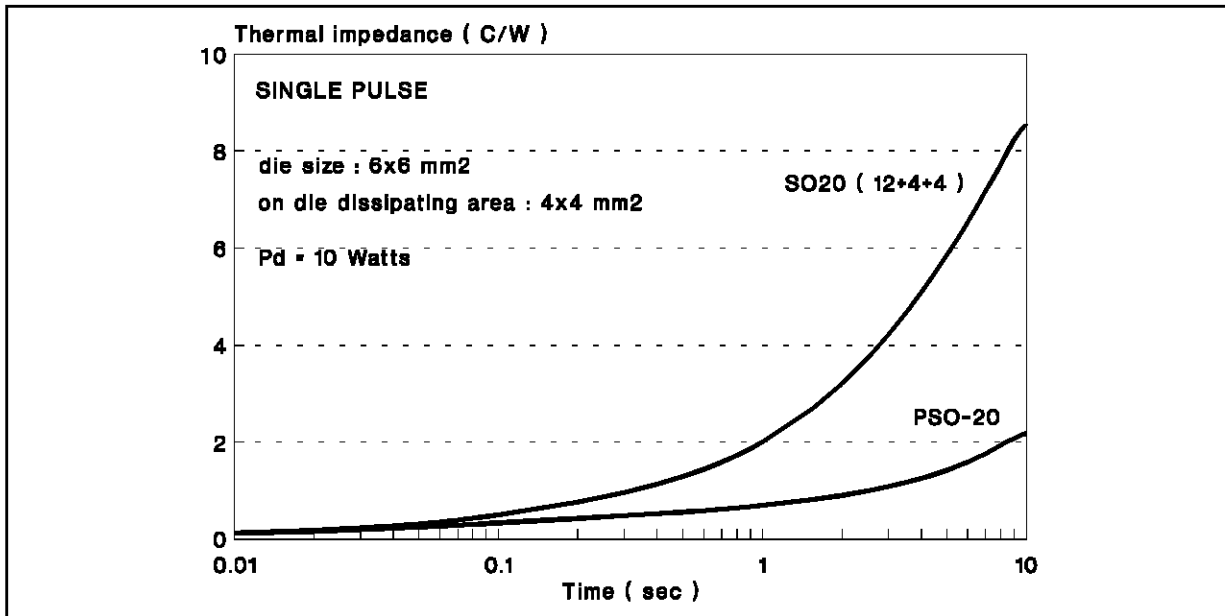

Figure 23: Thermal impedance of PowerSO-20 and standard SO20



4. SOLDERING INFORMATION

The soldering process causes considerable thermal stress to a semiconductor component. This has to be minimized to ensure a reliable and extended lifetime of the device.

The PowerSO-20 package can be exposed to a maximum temperature of 260°C for 10 seconds. Correct soldering of the package is guaranteed at 215°C for 3 seconds after 8 hours steam aging or after 16 hours dry aging at 155°C. Any solder

temperature profile should be within these limits.

As infrared reflow techniques are the most common in surface mounting, typical heating profiles are given in Figure 24, with a preheating at 130 - 150°C for 80 - 100 seconds, either for mounting on FR4 epoxy substrate or mounting on metal-backed boards (IMS). Peak temperature should be at least 30°C higher than the melting point of the solder chosen.

Figure 24: Typical reflow soldering heat profile

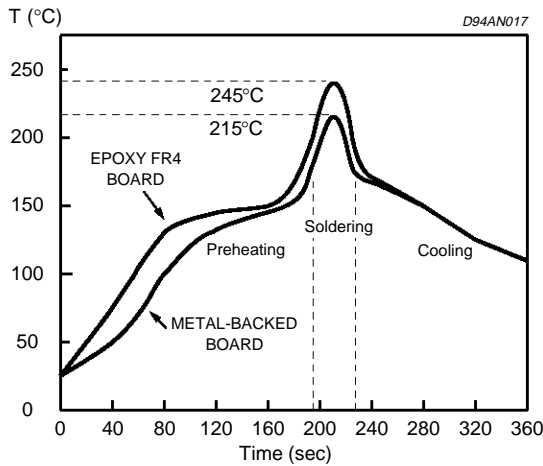

5. RELIABILITY DATA

The information presented in this section shows that the PowerSO-20 is able to work reliably in severe environments, like automotive, where the requested reliability target is 1 ppm failure rate.

In order to evaluate the reliability behavior of the present package a complete qualification program was compiled with two test vehicles:

- TDA7350A (Audio Power Amplifier)
- ABS voltage regulator

A list of the tests, their features and the failure modes associated to these tests is given in Table 4. Tables 5 and 6 show the results of the qualification; all the package and die oriented tests were passed successfully. The test conditions and acceptance criteria are the same as those for standard power packages.

Table 4: Reliability tests description.

Test	Features	Purpose
High Temperature Reverse Bias (H.T.R.B.)	Reverse biased device at elevated temperature	To detect surface defects like poor passivation and contamination
Operating Life Test (O.L.T.)	Device submitted to application conditions	To put in evidence thermomechanical stresses induced by internal power dissipation
Thermal Humidity Bias (T.H.B.)	Biased in presence of steam	Metal corrosion detection
Power ambient	Detect cracked die, wire bond breaking, mechanical damage to package	
Pressure Pot Test (P.P.T.)	High temperature and pressure with saturated steam	Electrochemical and galvanic corrosion
Solderability Test (S.T.)	Verifies tinning process	Detects poor solder joint
Environmental Sequence (E.S.)	Thermal cycling combined with pressure pot	To study corrosion mechanism after thermal cycling stress
Surface Mount (S.M.)	Simulation of soldering process in the presence of humidity	To point out the package resistance to the stresses due to surface mounting in presence of humidity
Resistance to Solvents (R.S.)	Mil-Std-883 Meth. 2015	To verify the marking permanency

APPLICATION NOTE

Table 5: ABS Voltage Regulator (die size 5.3 x 5.28mm).

Test	Condition	Sample	Duration	Failure
T.C.T.	$T_{amb} = -65^{\circ}\text{C}$ to $+150^{\circ}\text{C}$ air to air	153 pcs. x 3 lots 153 pcs. x 1 lots	1000 cy 2000 cy	0 0
T.S.T.	$T_{amb} = -65^{\circ}\text{C}$ to $+150^{\circ}\text{C}$ liquid to liquid	60 pcs. x 3 lots	1000 cy	0
P.P.T.	$T_{amb} = 121^{\circ}\text{C}$ P = 2atm	77 pcs. x 3 lots	500hr	0
S.T. 1	$T_{amb} = 215^{\circ}\text{C}$; precond. 8h vapor	22 pcs. x 3 lots	-	0
S.T. 2	$T_{amb} = 215^{\circ}\text{C}$; precond. 16h vapor at $T_{amb} = 155^{\circ}\text{C}$	22 pcs. x 3 lots	-	0
E.S.	100cy at -65°C to $+150^{\circ}\text{C}$ 48hr of PPT at 3atm (5 Times Repeated)	25 pcs. x 3 lots	-	0
S.M.	24hr at $85^{\circ}\text{C}/85\%$ dipping at 260°C 10" 48h PPT at 2.5atm	22 pcs. x 3 lots	-	0
R.S.	Mil-Std-883 Meth 2015	22 pcs. x 3 lots	-	0

Table 6: TDA7350A (Bridge Audio Amplifier).

Test	Condition	Sample	Duration	Failure
H.T.R.B.	$V_s = 18\text{V}$; $T_J = 150^{\circ}\text{C}$	77 pcs. x 3 lots	200hr	0
O.L.T.	$V_s = 16\text{V}$; $P_d = 10\text{W}$; $T_J = 150^{\circ}\text{C}$	90 pcs. x 3 lots	2000hr	0
T.H.B.	$V_s = 14\text{V}$; $T_{amb} = 85^{\circ}\text{C}$; R.H. = 85%	77 pcs. x 3 lots	2000hr	0
P.T.C.	$V_s = 14\text{V}$; $t_{on} = t_{off} = 5''$ $T_{amb} = -40$ to $+85^{\circ}\text{C}$;	30 pcs. x 3 lots	1000hr	0

6. CONCLUSION

The PowerSO-20 package, a new surface mount power package, has been introduced.

It has been designed specifically for the surface mount industry and it can replace Multiwatt in many applications.

The main advantages of the PowerSO-20 are:

1. Good thermal characteristics. It is able to handle die with the same size as Multiwatt.
2. Versatility. A wide variety of intelligent power products with a wide range of options can be managed.
3. Symmetrical package design. Slug up and slug down versions can be delivered giving more opportunities to the customers for

power dissipation.

4. High power density through reduced package volume and height.
5. Compatibility with automatic placement equipment and soldering techniques used in surface-mount assembly. Reliable and inspectable solder joints can be achieved.
6. High reliability in terms of hermeticity. The correct choice of the materials and particular design features allow the PowerSO-20 to pass successfully severe tests like pressure pot and die penetrant.

It was demonstrated that this package well meets the high demands in surface-mount power applications, where power ICs are becoming more and more common.

APPLICATION NOTE

Information furnished is believed to be accurate and reliable. However, SGS-THOMSON Microelectronics assumes no responsibility for the consequences of use of such information nor for any infringement of patents or other rights of third parties which may result from its use. No license is granted by implication or otherwise under any patent or patent rights of SGS-THOMSON Microelectronics. Specifications mentioned in this publication are subject to change without notice. This publication supersedes and replaces all information previously supplied. SGS-THOMSON Microelectronics products are not authorized for use as critical components in life support devices or systems without express written approval of SGS-THOMSON Microelectronics.

© 1994 SGS-THOMSON Microelectronics - All Rights Reserved

SGS-THOMSON Microelectronics GROUP OF COMPANIES

Australia - Brazil - France - Germany - Hong Kong - Italy - Japan - Korea - Malaysia - Malta - Morocco - The Netherlands - Singapore - Spain - Sweden - Switzerland - Taiwan - Thailand - United Kingdom - U.S.A.